

APS Guide



**Energy-
Efficient
Lighting for
Commercial
Applications**



**High Bay and Low Bay
Lighting
Section**

LURA LINE
LIGHTING



INTRODUCTION

Luraline Lighting is proud to introduce **APS: A Product Specifier's Guide to Energy-Efficient Lighting for Commercial Applications**. The guide features hundreds of lighting fixtures designed to meet today's demanding efficiency and performance standards, while offering the specifier a multitude of options for fixture styles, lamp types, wattages, efficacy and longevity.

ABOUT Us...

You can specify with confidence, knowing that Luraline Lighting has manufactured quality products in the USA since 1967. Our company headquarters in South Florida includes a 30,000-square-foot production facility with CAD equipment and full custom capabilities. Regardless of the size or scope of the project, we pride ourselves on customer service and an attention to detail that ensures a successful lighting installation.

OUR PRODUCTS...

In addition to the commercial fixtures in this guide, Luraline Lighting manufactures a full line of products for hospitality, contract, retail, restaurant, healthcare, educational, institutional and multi-family residential applications.

We offer an extensive selection of lighting fixtures suitable for exterior and interior installations. Fixtures are available in pendant, ceiling, sconce, wall and post-mount configurations, with a broad range of choices for lamping and diffusers, optional accessories, and colors, tones and finish textures.











Luraline Lighting combines energy-efficient lamping with durable construction and materials that maximize energy savings while minimizing repair and replacement costs. We utilize the latest in high-efficiency light sources, including electronically driven compact fluorescent, HID, LED and induction lamping.



TABLE OF CONTENTS

Introduction.....ii
Lighting and the Environment iv

OUR PRODUCTS

	Cutoff Wall Mounts	A2 - 5, A7 - 11
	Bulkheads	A13 - 25
	Wall Packs	A6, A12, A26 - 40
	Flood Lights	A42 - 56
	Area and Roadway Lighting	A58 - 79
	Bollards, Poles and Accessories	A80 - 86
	Parking Garage Lights	A88 - 89
	Vandal Resistant Fixtures	A90 - 95
	Vapor Proof Fixtures	A96 - 102
	High Bay and Low Bay Lighting	A104 - 108

APPENDIX

About High Performance Lighting	a1
Light Source Comparisons	a2 - 3
Light Source Overviews and Recommendations	a4 - 7
Lighting Organizations and Resources	a8 - 9
Numerical Product Index	a10 - 11



LIGHTING AND THE ENVIRONMENT

Luraline Lighting is proud to be part of the movement toward increased energy efficiency, which represents one of the lighting industry's most important contributions toward green design and the sustainable building movement.

Luraline has focused on producing energy-efficient, high-performance lighting fixtures for more than four decades. The company views its longtime commitment toward eco-efficiency as an integral part of providing the highest quality and value to its customers.

Continuing technical advances have resulted in lamping options that are more cost-effective and yet perform as well or better than older methods. While some of the new lamping sources may cost more initially, the resulting energy savings provide an excellent return on investment for new builds and remodels. In addition, the installation of longer-life lamps minimizes replacement costs as well as labor and operating expenses.

As Luraline continues to evolve along with the lighting industry, the company will keep pace with emerging technologies and materials in order to support both its environmental initiatives and to maximize the bottom-line costs savings for its clients.

Luraline Lighting is a proud member of organizations at the forefront of our industry's environmental initiatives:



USGBC and related logo is a trademark owned by the U.S. Green Building Council and is used by permission.

In consideration of the environment, this guide was printed with soy ink and in a reduced size to conserve paper.



HIGH BAY AND LOW BAY LIGHTING

Luraline high bay fixtures are designed to meet long-life, low-maintenance performance requirements for general area lighting of large-scale applications with above-average (20+ feet) ceiling heights. Our low bay collection provides high-quality illumination of spaces with low-to-medium ceiling heights (under 20 feet). Fixtures are offered in a variety of configurations with energy-efficient lamping options including EISA-compliant pulse-start metal halide, multiple-lamp compact fluorescent, T5HO fluorescent, 100,000-hour induction and high-pressure sodium. High bay and low bay lights are mounted on hooks, chains or with swivel canopy, depending on model, with optional cord sets also available.



Larger-sized PDF files, product cut-sheets and detailed photometric data available at www.luraline.com.

22" Compact Fluorescent High/Low Bay

AHBCR22



AHBCR22-OL

Housing: Heavy duty round die-cast aluminum housing, white powdercoat finish over a chromate conversion coating, 3/4" threaded hole on top for hook or stem installation, side coin plugs for conduit or cord access.

Reflector: White powdercoat steel pan reflector with 22" diameter clear prismatic acrylic refractor
Lens: Standard models are bare-lamp (open bottom) or optional acrylic conical lens (CL), or acrylic drop lens (DL). Lenses retained by aluminum clamp band

Socket: Plug-in type, GX24Q-3/-4

Mounting: Mount on 3/4" malleable hook (included) or optional swivel canopy

Wattage: Compact Fluorescent: 6 x 26 to 42w, 8 x 26 to 42w

Listings & Ratings: CSA Listed for dry locations.

Photometrics

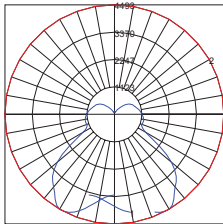

AHBCR22F842E-OL

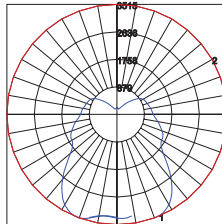

AHBCR22F842E-DL

Catalog #	Wattage	Lamp	Optional Lenses*
AHBCR22F626E-OL	6 x 26	CF	CL, DL
AHBCR22F632E-OL	6 x 32	CF	CL, DL
AHBCR22F642E-OL	6 x 42	CF	CL, DL
AHBCR22F826E-OL	8 x 26	CF	CL, DL
AHBCR22F832E-OL	8 x 32	CF	CL, DL
AHBCR22F842E-OL	8 x 42	CF	CL, DL

All models supplied with 120-277V electronic ballasts

Dimensions

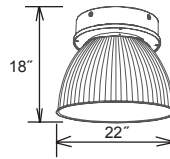

AHBCR-OL

Options and Accessories

Catalog #	Description	
CL	22 x 2 1/2" Prismatic Acrylic Conical Lens with clamp band	*To order, replace "OL" suffix with desired lens code
CPCS16310P110	Cord Set, 3-Prong Polarized, 10' Cord	
CPCS1633	Cord Set, Blunt Cut, 3', 16/3 600V STW Cord	
CPCS1633P120	Cord Set 120v Twist-Lock L5-15P Plug, 3' Cord	
CPCS1633P277	Cord Set 277v Twist-Lock L7-15P Plug, 3' Cord	
CPSPR	Round Swivel Canopy, Fits 3/4" Conduit**	
CPSPS	Square Swivel Canopy, Fits 3/4" Conduit**	
DL	22 x 3 3/4" Prismatic Acrylic Drop Lens with clamp band	*To order, replace "OL" suffix with desired lens code
HBRAR22WG	22 x 5" Wire Guard (for use with AHB11ACR22 "OL" models only)	

**Conduit Stems available by special order only - please consult factory

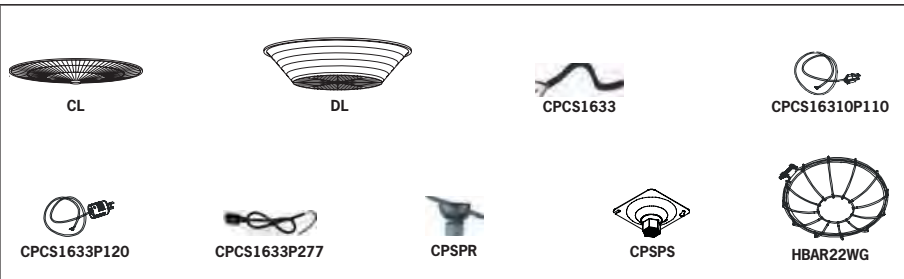

Specifications subject to change without notice.

AL

T5 Fluorescent High Bay

Housing: ALC - formed I-Frame, white powdercoat steel, includes rear wiring access with quick connect, knockouts for twin pendant mounting & occupancy sensor (Not included)
 ALB models include end caps
 ALA models include end caps and side panels
Reflector: Specular high performance aluminum reflector
Socket: T5 fluorescent sockets
Mounting: Chain mount from corners or from two center V-brackets or Twin stems (optional)
Wattage: 4 x 54w or 6 x 54w
Listings & Ratings: CSA Listed for dry locations

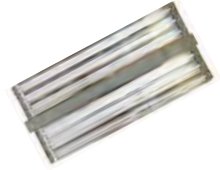

Catalog #	Wattage	Voltage	Lamp	Ballast
ALC454T5HO	4 x 54	120-277	T5HO	Electronic
ALC654T5HO	6 x 54	120-277	T5HO	Electronic

Lamps not included

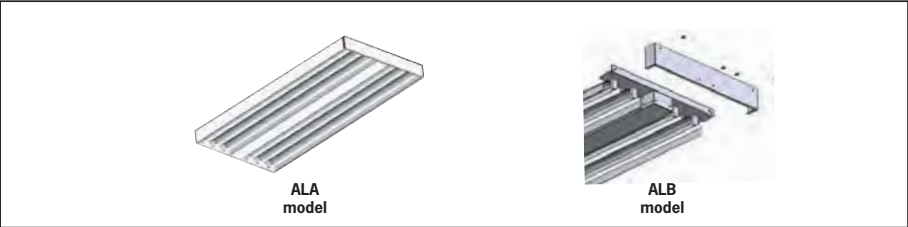
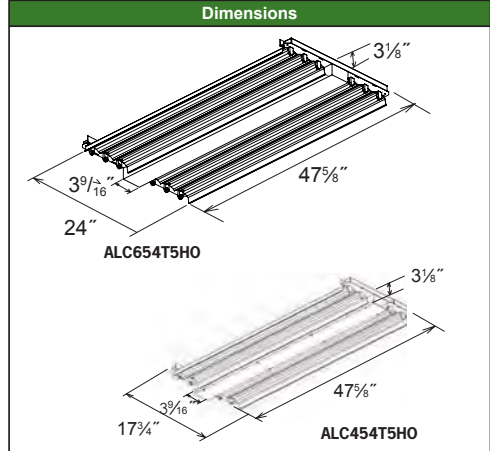
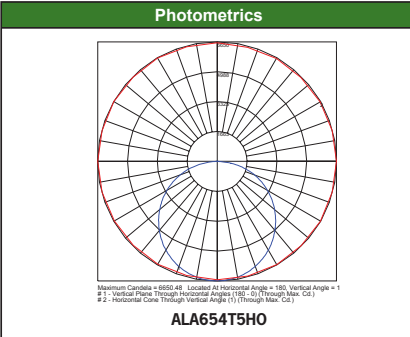

Options and Accessories

Catalog #	Description
CPSPR	Round Swivel Canopy, Fits 3/4" Conduit**
CPSPS	Square Swivel Canopy, Fits 3/4" Conduit**
CPCS16310P110	Cord Set, 3-Prong Polarized, 10' Cord
CPCS1633	Cord Set, Blunt Cut, 3', 16/3 600V STW Cord
CPCS1633P120	Cord Set 120v Twist-Lock L5-15P Plug, 3' Cord
CPCS1633P277	Cord Set 277v Twist-Lock L7-15P Plug, 3' Cord

**Conduit Stems available by special order only - please consult factory



Specifications subject to change without notice.

16" Low Bay

ALB20



ALB20AR16-DL
(shown with Drop Lens)

Housing: Heavy duty die-cast aluminum housing, white powdercoat finish over chromate conversion coating, electrical box with malleable hook

Reflector: Anodized aluminum reflector (AR) or clear prismatic acrylic refractor (ACR)

Lens: Standard models are bare-lamp (open bottom) and supplied with Open-Rated lamp and socket. Choice of flat tempered glass lens with gasket (GL), acrylic conical lens (CL), or acrylic drop lens (DL). Lenses retained by aluminum clamp band

Socket: 5KV pulse rated mogul base socket with nickel-plated screw shell and socket plate

Mounting: Mount with included malleable hook or optional swivel canopy. (Conduit Stems available by special order - please consult factory)

Wattage: High Pressure Sodium: 100 to 400w

Pulse-start / Metal Halide: 100 to 400w

Listings & Ratings: CSA Listed for dry locations

Dimensions	Photometrics
<p>ALB20ACR16-OL</p>	<p>ALB20AR16MH400</p> <p><small>Maximum Candela = 441 1. Vertical Angle Through Horizontal Angle 0° - 0° (Through Max. Cd) 2. Horizontal Angle Through Vertical Angle 0° - 0° (Through Max. Cd) 3. Horizontal Angle Through Vertical Angle 0° - 0° (Through Min. Cd) 4. Horizontal Angle Through Vertical Angle 0° - 0° 5. Horizontal Angle Through Vertical Angle 0° - 0°</small></p>

Items marked with meet EISA regulations for 150-500 watt Metal Halide luminaires.

Catalog #	Wattage	Lamp	Optional Lenses*
Aluminum Reflector Models:			
ALB20AR16H100Q-OL	100	HPS	CL, DL, GL
ALB20AR16H150Q-OL	150	HPS	CL, DL, GL
ALB20AR16H250Q-OL	250	HPS	CL, DL, GL
ALB20AR16H400Q-OL	400	HPS	CL
ALB20AR16M100Q-OL	100	MH	CL, DL, GL
ALB20AR16P250Q-OL	250	PS	CL, DL, GL
ALB20AR16P320Q-OL	320	PS	GL
ALB20AR16P400Q-OL	400	PS	CL
Acrylic Refractor Models:			
ALB20ACR16H100Q-OL	100	HPS	CL, DL
ALB20ACR16H150Q-OL	150	HPS	CL, DL
ALB20ACR16H250Q-OL	250	HPS	CL, DL
ALB20ACR16M100Q-OL	100	MH	CL, DL
ALB20ACR16P250Q-OL	250	PS	CL, DL
All models supplied with Quad-Tap ballasts (120/208/240/277V)			

Options and Accessories

Catalog #	Description	
CL	16 x 1 1/2" Prismatic Acrylic Conical Lens with clamp band	*To order, replace "OL" suffix with desired lens code
CPCS16310P110	Cord Set, 3-Prong Polarized, 10' Cord	
CPCS1633	Cord Set, Blunt Cut, 3', 16/3 600V STW Cord	
CPCS1633P120	Cord Set 120v Twist-Lock L5-15P Plug, 3' Cord	
CPCS1633P277	Cord Set 277v Twist-Lock L7-15P Plug, 3' Cord	
CPSPR	Round Swivel Canopy, Fits 3/4" Conduit**	
CPSPS	Square Swivel Canopy, Fits 3/4" Conduit**	
DL	16 x 2 1/2" Prismatic Acrylic Drop Lens with clamp band	*To order, replace "OL" suffix with desired lens code
GL	16" Tempered Glass with gasket and clamp band	*To order, replace "OL" suffix with desired lens code
HBAR16WG	16" Wire Guard (for use with ALB20AR16 "OL" models only)	
**Conduit Stems available by special order only - please consult factory		

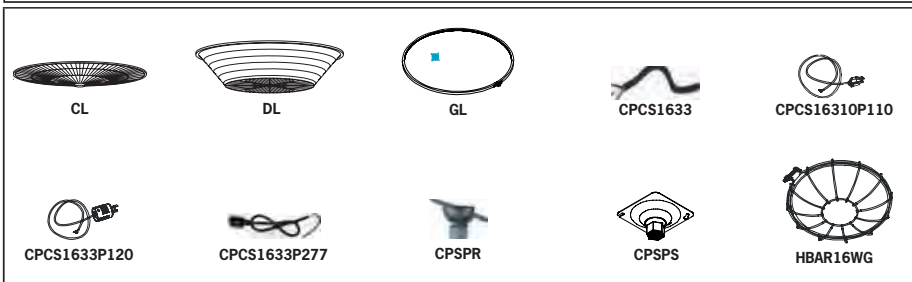

Specifications subject to change without notice.

AHB11

16" High Bay

Housing: Heavy duty die-cast aluminum housing, white powdercoat finish over chromate conversion coating, electrical box with malleable hook

Reflector: Anodized aluminum reflector (AR) or clear prismatic acrylic refractor (ACR)

Lens: Standard models are bare-lamp (open bottom) and supplied with Open-Rated lamp and socket. Choice of flat tempered glass lens with gasket (GL), acrylic conical lens (CL), or acrylic drop lens (DL). Lenses retained by aluminum clamp band.

Socket: 5KV pulse rated mogul base socket with nickel-plated screw shell and socket plate

Mounting: Mount with included malleable hook or optional swivel canopy. (Conduit Stems available by special order - please consult factory)

Wattage: High Pressure Sodium: 100 to 400w

Pulse-start / Metal Halide: 100 to 400w

Listings & Ratings: CSA Listed for dry locations



AHB11AR16-OL

AHB11ACR16-OL

Catalog #	Wattage	Lamp	Optional Lenses*
Aluminum Reflector Models:			
AHB11AR16 H100Q-OL	100	HPS	CL, DL, GL
AHB11AR16H150Q-OL	150	HPS	CL, DL, GL
AHB11AR16H250Q-OL	250	HPS	CL, DL, GL
AHB11AR16H400Q-OL	400	HPS	CL
AHB11AR16M100Q-OL	100	MH	CL, DL, GL
AHB11AR16P250Q-OL	250	PS	CL, DL, GL
AHB11AR16P320Q-OL	320	PS	GL
AHB11AR16P400Q-OL	400	PS	CL
Acrylic Refractor Models:			
AHB11ACR16H100Q-OL	100	HPS	CL, DL
AHB11ACR16H150Q-OL	150	HPS	CL, DL
AHB11ACR16H250Q-OL	250	HPS	CL, DL
AHB11ACR16M100Q-OL	100	MH	CL, DL
AHB11ACR 16P250Q-OL	250	PS	CL, DL
All models supplied with Quad-Tap ballasts (120/208/240/277V)			

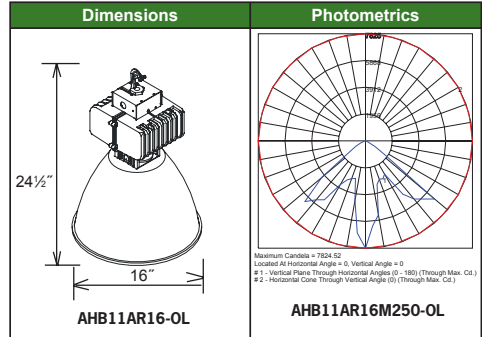

Items marked with meet EISA regulations for 150-500 watt Metal Halide luminaires.

Options and Accessories

Catalog #	Description	
CL	16 x 1 1/2" Prismatic Acrylic Conical Lens with clamp band	*To order, replace "OL" suffix with desired lens code
CPCS16310P110	Cord Set, 3-Prong Polarized, 10' Cord	
CPCS1633	Cord Set, Blunt Cut, 3', 16/3 600V STW Cord	
CPCS1633P120	Cord Set 120v Twist-Lock L5-15P Plug, 3' Cord	
CPCS1633P277	Cord Set 277v Twist-Lock L7-15P Plug, 3' Cord	
CPSPR	Round Swivel Canopy, Fits 3/4" Conduit**	
CPSPS	Square Swivel Canopy, Fits 3/4" Conduit**	
DL	16 X 2 1/2" Prismatic Acrylic Drop Lens with clamp band	*To order, replace "OL" suffix with desired lens code
GL	16" Tempered Glass with gasket and clamp band	*To order, replace "OL" suffix with desired lens code
HBAR16WG	16" Wire Guard (for use with ALB20AR16 "OL" models only)	
**Conduit Stems available by special order only - please consult factory		

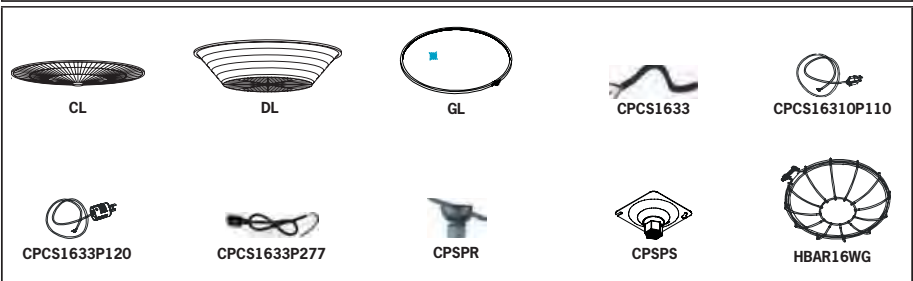

Specifications subject to change without notice.

22" High Bay

AHB11



AHB11AR22-OL



AHB11ACR22-OL

Housing: Heavy duty die-cast aluminum housing, white powdercoat finish over chromate conversion coating, electrical box with malleable hook

Reflector: Anodized aluminum reflector (AR), High Performance faceted aluminum (FAR) or clear prismatic acrylic refractor (ACR)

Lens: Standard models are bare-lamp (open bottom) and supplied with Open-Rated lamp and socket. Choice of flat tempered glass lens with gasket (GL), acrylic conical lens (CL), or acrylic drop lens (DL). Lenses retained by aluminum clamp band.

Socket: HID: 5KV pulse rated mogul base socket with nickel-plated screw shell and socket plate

Mounting: Mount with included malleable hook or optional swivel canopy. (Conduit Stems available by special order - please consult factory)

Wattage: High Pressure Sodium: 250 to 400w.
Induction: 120 or 200w
Pulse-start / Metal Halide 250 to 400w

Listings & Ratings: CSA Listed for dry locations.

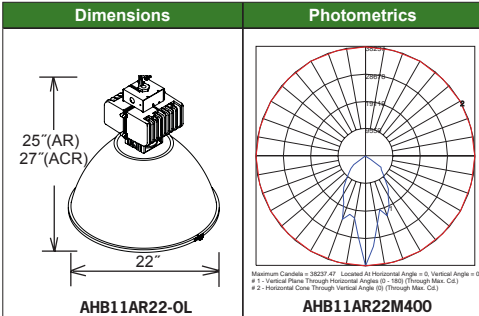

HID models supplied with Quad-Tap ballast (120/208/240/277V).
Induction models supplied with choice of 120 or 277V electronic ballasts.
Please specify desired voltage when ordering.

Items marked with meet EISA regulations for 150-500 watt Metal Halide luminaires.

Catalog #	Wattage	Lamp	Optional Lenses*
Aluminum Reflector Models:			
AHB11AR22H250Q-OL	250	HPS	CL, DL, GL
AHB11AR22H400Q-OL	400	HPS	CL, DL, GL
AHB11AR22P250Q-OL	250	PS	CL, DL, GL
AHB11AR22P320Q-OL	320	PS	CL, DL, GL
AHB11AR22P400Q-OL	400	PS	CL, DL, GL
AHB11FAR22H400Q-OL	400	HPS	HL
AHB11FAR22P400Q-OL	400	PS	HL
Acrylic Refractor Models:			
AHB11ACR16H250Q-OL	250	HPS	CL, DL
AHB11ACR16P250Q-OL	250	PS	CL, DL
AHB11ACR22P320Q-OL	320	PS	CL, DL
AHB11ACR22P400Q-OL	400	PS	CL, DL
AHB11ACR22I120-OL	120	IND	CL, DL
AHB51ACR22I200-OL	200	IND	CL, DL

Options and Accessories

Catalog #	Description	
CL	22" Prismatic Acrylic Conical Lens with clamp band	*To order, replace "OL" suffix with desired lens code
CPCS16310P110	Cord Set, 3-Prong Polarized, 10' Cord	
CPCS1633	Cord Set, Blunt Cut, 3', 16/3 600V STW Cord	
CPCS1633P120	Cord Set 120v Twist-Lock L5-15P Plug, 3' Cord	
CPCS1633P277	Cord Set 277v Twist-Lock L7-15P Plug, 3' Cord	
CPSPR	Round Swivel Canopy, Fits 3/4" Conduit**	
CPSPS	Square Swivel Canopy, Fits 3/4" Conduit**	
DL	22" Prismatic Acrylic Drop Lens with clamp band	*To order, replace "OL" suffix with desired lens code
GL	22" Tempered Glass with gasket and clamp band	*To order, replace "OL" suffix with desired lens code
HBAR22WG	22" Wire Guard (for use with HB11AR22-"OL" models only)	
HL	22" Hinged Tempered Glass Lens with gasket (HB11FAR models only)	*To order, replace "OL" suffix with desired lens code
**Conduit Stems available by special order only - please consult factory		

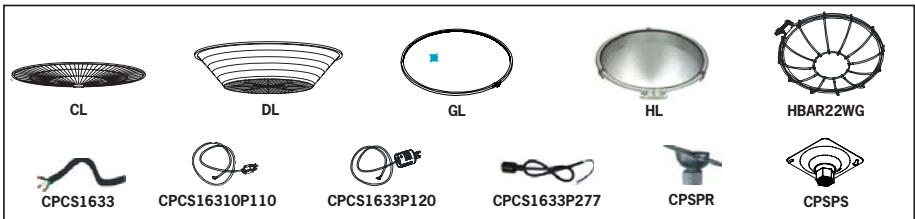

Specifications subject to change without notice.

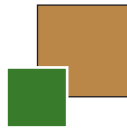

ABOUT HIGH PERFORMANCE LIGHTING

Lighting plays a critical role in the ever-evolving standards and practices of Green Building and Sustainable Design. Increased environmental awareness in the public and private sectors, coupled with developments in technology, has impacted the criteria for lighting specifications.

The focus is on “High-Performance Lighting,” or lighting that is both efficient and effective. Lighting fixtures are a key component of a total lighting solution, which incorporates energy-efficient light sources, then uses them to their best advantage by maximizing delivered lumens while reducing Light Pollution. The goal is to achieve lighting objectives while reducing energy and maintenance costs, and with an added emphasis on value and long-term environmental benefits.

The “High-Performance Lighting” design process is inclusive of the entire building project, its purposes and functions, and the needs of the people involved. The specifier should consider the number and type of fixtures, and the use of such features as enhanced reflectors and optics, and sensors and lighting control systems. Many installations benefit from the use of Cutoff lighting fixtures that allow the user to further direct and adjust light levels and distribution patterns.

The choice of light source for a high-performance lighting installation depends on a number of factors including lumen maintenance, color stability, and rated average lamp life, as well as environmental concerns such as energy efficiency and low mercury content.

This catalog features a wide range of high-performance, energy-efficient lighting, including a wide selection of Cutoff fixtures that comply with current Green Building Standards.



LIGHT SOURCE COMPARISONS

(SORTED BY LUMEN OUTPUT)

Light Source	Lamp Wattage	Lumen Output	Lamp Life	Lumens Per Watt (Efficacy)
LED (1 x 15w)	15	700	50000	46
Incandescent (A)	60	890	1000	15
Compact Fluorescent	13	900	12000	69
Halogen (A-Hal)	50	965	3000	19

LED (2 x 7.5w)	15	1000	50000	66
Incandescent (A)	75	1220	750	16
Compact Fluorescent	18	1250	12000	69
Halogen (A-Hal)	75	1315	3000	18

LED (3 x 7.5w)	22.5	1500	50000	66
Incandescent (A)	100	1600	750	16
Halogen (A-Hal)	100	1800	3000	18
Compact Fluorescent	26	1800	16000	69

Compact Fluorescent	32	2400	16000	75
Incandescent (A)	150	2740	750	18
LED (4 x 15w)	60	2800	50000	46
Induction	40	2800	100000	70
Compact Fluorescent	42	3200	16000	76

LED (5 x 15w)	75	3500	50000	46
Incandescent (A)	200	3850	750	19
Pulse-start Metal Halide	50	4100	16000	82
Compact Fluorescent	57	4300	16000	75

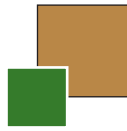

LIGHT SOURCE COMPARISONS

(SORTED BY LUMEN OUTPUT)

Light Source	Lamp Wattage	Lumen Output	Lamp Life	Lumens Per Watt (Efficacy)
LED (8 x 15w)	120	5600	50000	46
Incandescent (A)	300	5860	750	20
Pulse-start Metal Halide	70	6200	16000	89
Induction	80	6400	100000	80
Pulse-start Metal Halide	100	9500	16000	95
Induction	120	9600	100000	80
Induction	150	12000	100000	80
Pulse-start Metal Halide	150	14000	16000	93
Pulse-start Metal Halide	175	16000	15000	91
T5HO (4 x 54w)	216	17800	25000	82
Induction	200	18000	100000	90
Pulse-start Metal Halide	250	23750	15000	95
T5HO (6 x 54w)	324	26700	25000	82
Pulse-start Metal Halide	320	30000	20000	94
Pulse-start Metal Halide	400	42600	20000	107
Pulse-start Metal Halide	750	82000	16000	110
Pulse-start Metal Halide	1000	120000	15000	120



METAL HALIDE LIGHTING



Metal Halide provides the whitest light and best color rendering of the High Intensity Discharge (HID) lamping category, and metal halide pulse-start technology, which has virtually replaced conventional probe-starts, has even greater benefits. Pulse-start metal halide lamps provide increased efficiency and longer lamp life, thereby lowering both replacement and lifetime operating costs. Higher initial light levels and an up to 40 percent improvement in maintained light over time means lighting requirements are fulfilled with fewer total fixtures. Additional pluses include faster warm-up and re-strike times, better cold weather starts, and a wide range of available pulse-start lamps and ballasts from 20 to 1,000 watts.

Luraline Pulse-Start products between 150 and 500 watts comply with the Energy Independence and Security Act (EISA) of 2007.

Please consider the environment, when selecting light sources:

Instead of Probe Start	Use Pulse-Start Metal Halide	Energy Savings	Lumen Output	Lamp Life
175 Watt	150 Watt	15%	122%	150%
250 Watt	175 Watt	30%	85%	150%
250 Watt	250 Watt	0%	120%	150%
400 Watt	320 Watt	20%	80%	120%
400 Watt	400 Watt	0%	118%	120%

Instead of Probe Start	Use F54T5HO Fluorescent	Energy Savings	Lumen Output	Lamp Life
250 Watt	4x54 Watt	15%	88%	200%
400 Watt	6x54 Watt	18%	75%	125%

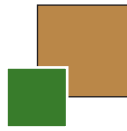

FLUORESCENT LIGHTING



Fluorescent fixtures are designed to meet illumination requirements while significantly lowering operating costs and complying with mandated energy usage standards. Fluorescent lamps last up to 20 times longer and are up to six times more efficient than traditional incandescent bulbs. Upgrading from incandescent to compact fluorescent saves up to 79 percent in energy costs without any sacrifice in quality or color rendering. Most fluorescent lamps are also available with low mercury content.

Because they can be used in traditional light-bulb sockets, compact fluorescent lamps are the preferred choice for retrofits of existing incandescent fixtures. However, please note that fixtures utilizing dedicated fluorescent sockets, ballasts and lamps are preferred whenever possible due to greater efficiency and longevity than their screw-in or GU-24 based compact fluorescent counterparts.

Please consider the environment, when selecting light sources:

Instead of Incandescent	Use Compact Fluorescent	Energy Savings	Lumen Output	Lamp Life
60 Watt	13 Watt	73%	100%	1200%
75 Watt	13 Watt	79%	74%	1600%
75 Watt	18 Watt	72%	102%	1600%
100 Watt	26 Watt	69%	112%	1600%
150 Watt	32 Watt	75%	89%	2133%
150 Watt	42 Watt	69%	118%	2133%
200 Watt	42 Watt	77%	84%	2133%
200 Watt	57 Watt	69%	113%	2133%

Instead of Halogen Par	Use Compact Fluorescent	Energy Savings	Lumen Output	Lamp Life
50 Watt	13 Watt	68%	169%	400%
75 Watt	13 Watt	79%	90%	400%
75 Watt	18 Watt	72%	125%	400%
90 Watt	18 Watt	77%	110%	600%
120 Watt	26 Watt	74%	97%	640%



LED LIGHTING



For state-of-the-art, long-life, mercury-free fixtures, specify LED lamping. As technology advances and costs continue to drop, LEDs are evolving into a mainstream light source, whose ever-increasing life cycles and light output make them an intelligent choice for a variety of commercial applications.

The latest LEDs boast up to 100,000-hour life cycles plus efficacy of 100 lumens per watt and higher, thereby using significantly less energy than other light sources to produce a comparable amount of light, while dramatically lowering maintenance and operating costs. Low UV radiation and heat levels prolong fixture and component life even further, making LEDs one of the best options for UV-sensitive applications. LED lamps are also mercury-free and thus more environmentally sound than traditional HID and fluorescent.

Please consider the environment, when selecting light sources:

Instead of	Use LED	Energy Savings	Lumen Output	Lamp Life
75 Watt Incand	15 Watt	80%	95%	8000%
100 Watt Incand	22.5 Watt	77.5%	88%	10600%
200 Watt Incand	75 Watt	25%	206%	10600%
70 Watt MH Par	75 Watt	0%	95%	640%

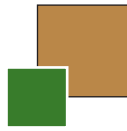

INDUCTION LIGHTING



Comparable to the newest energy-saving light sources, micro-electronically controlled electromagnetic induction lamps boast a rated average life of 100,000 hours, and high-lumen output that renders them virtually maintenance free. High-lumen maintenance rates an impressive 95 percent after 2,000 hours and 85 percent after 6,000 hours. High-frequency electronic ballasts, coupled with high system efficiency, reduce energy costs by up to 75 percent compared to HID, and up to 95 percent compared to incandescent. System efficiency of high-frequency electronic ballasts is 50 percent greater than magnetic ballasts. Additional benefits of induction lighting include excellent color rendition (CRI of 80+), instant on/off, starting temperatures as low as -35 degrees Celsius, and almost zero mercury content.

When long life is the top priority, specify induction lamping. Its extreme longevity makes it ideal for hard-to-reach areas such as street lights, warehouses, gymnasiums, and other high-height applications.

Please consider the environment, when selecting light sources:

Instead of	Use Induction	Energy Savings	Lumen Output	Lamp Life
150 Watt Incand	40 Watt	67%	102%	13300%
300 Watt Incand	80 Watt	67%	109%	13300%
100 Watt MH Par	80 Watt	20%	118%	800%
150 Watt MH Par	120 Watt	20%	105%	666%
175 Watt PSMH	150 Watt	15%	94%	870%
250 Watt PSMH	200 Watt	20%	90%	833%



LIGHTING ORGANIZATIONS AND RESOURCES

ILLUMINATING ENGINEERING SOCIETY (IESNA)

IESNA is the industry's premier lighting community dedicated to promoting the art and science of quality lighting to its members, allied professional organizations, and the public. The IESNA Lighting Handbook is the heart of a comprehensive library of technical standards and guides, which serves as benchmarks for residential and commercial building and energy code legislation.

<http://www.ies.org>

INTERNATIONAL DARK-SKY ASSOCIATION (IDA)

The IDA seeks to preserve dark skies worldwide for the benefit of society by promoting outdoor lighting standards that minimize light pollution, light trespass, and glare. IESNA has assisted IDA in its mission by establishing classifications for outdoor fixtures, measured by the amount of light wasted into the night sky: The percentage of lamp lumens released into the sky ranges from zero percent for Full-Cutoff rated fixtures, to 2.5 percent for Cutoff, 5 percent for Semi-Cutoff, and unrestricted lumens with Non-Cutoff rated fixtures. However, in addition to the IES classification, factors such as security, maintenance, energy efficiency, the spacing and number of fixtures, and the area's ground reflectance must also be considered when specifying the ideal Dark-Sky Friendly lighting fixture for an outdoor installation.

<http://www.darksky.org>

NATIONAL ELECTRICAL MANUFACTURERS ASSOCIATION (NEMA)

The electrical manufacturing industry's trade association provides a forum for the development of technical and performance standards; advocacy of industry policies on legislative and regulatory matters in state and federal legislatures and executive agencies; and collection, analysis, and dissemination of market data. NEMA played a key role in the development, passage and implementation of The Energy Independence and Security Act (EISA) and is continually involved in proposed legislation on environmental standards for the electrical industry.

<http://www.nema.org>

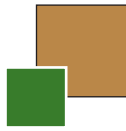

U.S. GREEN BUILDING COUNCIL (USGBC)

USGBC is dedicated to expanding green building practices and education and its **LEED®** (Leadership in Energy and Environmental Design) Green Building Rating System™ for developing high-performance, sustainable buildings. LEED addresses all building types and emphasizes state-of-the-art strategies in five areas: sustainable site development, water savings, energy efficiency, materials and resources selection, and indoor environmental quality. **LEED-EB®** for Existing Buildings offers certification for built structures through implementation of various energy performance methods.

<http://www.usgbc.org>

ENERGY STAR

America's most widely recognized energy efficiency program was created by the US Department of Energy and the Environmental Protection Agency in order to save money and reduce environmental impact through energy-efficient products and practices. Qualified lighting fixtures include those with fluorescent and LED light sources. Energy Star ratings also contribute toward certification of **LEED-EB®** projects for Existing Buildings, with **LEED®** credits awarded for raising the Energy Star rating of a built structure through implementation of various energy performance methods.

<http://www.energystar.gov>

ADDITIONAL RESOURCES

Today's rapidly developing construction technologies require near-constant code updates, including the National Electric Code, which standardizes various aspects of electrical construction; the energy standards established and jointly sponsored by the American Society of Heating, Refrigerating, and Air-Conditioning Engineers and the Illuminating Engineering Society of America, popularly known as ASHRAE/IESNA 90.1; and the new Green Building standards being adopted by local and regional governments across the US. This catalog features lighting fixtures and guidelines to assist you in the specification of compliant lighting products.



NUMERICAL PRODUCT INDEX

AA	AE	AFL905.....A75
AAD205.....A59	AEL10.....A101	AFL90F.....A74
AAD20F.....A58	AEL15.....A101	AFL90W.....A72
AAD405.....A60	AEL50.....A102	AH
AAD40C.....A61	AEL60.....A102	AHB11.....A107,108
AAD40W.....A62	AEP10.....A53	AHB51.....A108
AAL50C.....A63	AF	AHBRC22.....A104
AAL70C.....A68	AFL10.....A52	AL
AAL73.....A70	AFL31.....A50	ALA.....A105
AAL90C.....A73	AFL32.....A51	ALB.....A105
AB	AFL45.....A42	ALB20.....A106
AB1GR.....A13	AFL46.....A43	ALC.....A105
AB1OF.....A13	AFL50.....A47	ALF.....A54
AB1HC.....A13	AFL505.....A64	ALL121.....A85
AB1VC.....A13	AFL50F.....A65	ALL123.....A85
AB2OF.....A14	AFL50W.....A66	ALL131.....A85
AB2HC.....A14	AFL61.....A44	ALL133.....A85
AB2GR.....A14	AFL62.....A45	AP
ABOFL.....A84	AFL65.....A46	APF10.....A78
ABOFR.....A83	AFL70.....A48	APF50.....A79
ABOG.....A80	AFL705.....A71	APSS4.....A86
ABOL.....A82	AFL70F.....A67	AS
ABOR.....A81	AFL70W.....A69	ASL.....A55
	AFL90.....A49	ASP50.....A76,77

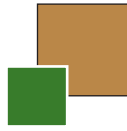

NUMERICAL PRODUCT INDEX

AT	AVP63.....A99	AWP34.....A4
ATN51.....A56	AVW23R1.....A96	AWP35.....A5
AV	AVW23R1F.....A97	AWP36.....A6
AVB23R1.....A96	AVW33R1.....A96	AWPA15.....A26
AVB23R1F.....A97	AVW33R1F.....A97	AWPA25.....A27
AVB33R1.....A96	AVW43.....A98	AWPB40.....A28
AVB33R1F.....A97	AVW53.....A100	AWPC10.....A10
AVB43.....A98	AVW63.....A99	AWPC15.....A7
AVB53.....A100	AW	AWPC20.....A8
AVB63.....A99	AWCD.....A12	AWPC25.....A9
AVN10.....A90	AWCS.....A11	AWPC35.....A2
AVN20.....A91	AWH15.....A33	AWPC36.....A3
AVN30.....A92,93	AWH20.....A34	AWPR22GR.....A18
AVN40.....A94,95	AWH25.....A35	AWPR22HC.....A19
AVN41.....A95	AWP10.....A36	AWPR22OF.....A20
AVNGL30.....A88	AWP12.....A37	AWPR40GR.....A17
AVNGL40.....A89	AWP13.....A32	AWPR40HC.....A16
AVP23R1.....A96	AWP14.....A31	AWPR40OF.....A15
AVP23R1F.....A97	AWP15.....A38	AWPS22GR.....A21
AVP33R1.....A96	AWP18C.....A24	AWPS22HC.....A22
AVP33R1F.....A97	AWP18O.....A25	AWPS22OF.....A23
AVP43.....A98	AWP20.....A39	AWPS30.....A29
AVP53.....A100	AWP25.....A40	AWPS40.....A30



Manufacturers of Quality Products Since 1967

2388 Northwest 150th Street
Opa Locka, Florida 33054

Phone: 800.940.6588
Fax: 305.685.6500

www.luraline.com

*In consideration of the environment,
this guide was printed with soy ink and in a
reduced size to conserve paper.*